

Threaded-Body Work Support

M 30 x 1.5, metallic wiper edge, 2 sizes, 3 types of function, single acting, max. operating pressure 500 bar

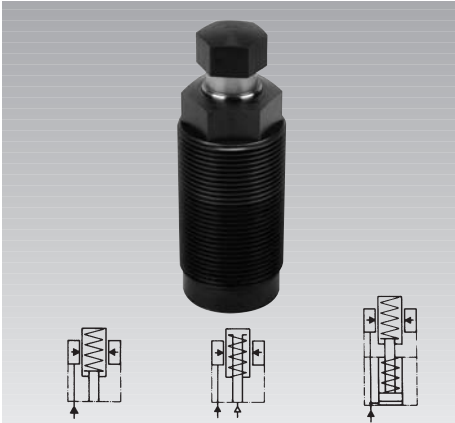

Advantages

- Space-saving threaded-body version
- 2 sizes
- 3 types of function
- Contact force by spring or pneumatically adjustable (1941-0X2)
- Load force 6.5 or 9.5 kN
- Metallic wiper edge and FKM wiper
- Corrosion-resistant interior parts
- Mounting body as accessory

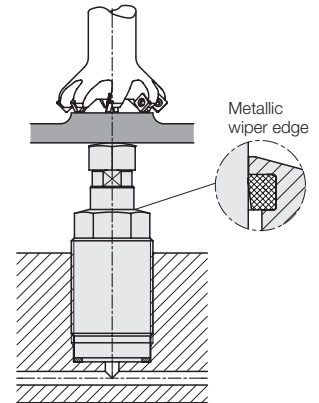

Application

Hydraulic work supports are used to provide a self-adjusting rest for the workpiece during the machining operations. They compensate the workpiece surface irregularities, also vibration and deflection under machining loads.

The threaded-body design allows for space-saving and direct installation into the fixture body. Oil supply is made through drilled channels.

Description

In the body of the threaded-body work support a thin-walled locking bush is integrated, which locks cylindrically around the freely-movable support plunger when pressurising the element with hydraulic oil.

There are three variations of plunger actuation:

1. Spring force
2. Air pressure
3. Oil pressure combined with spring force

The elements are protected against penetration of swarf by a metallic wiper edge and are sealed against liquids.

Important notes!

Work supports are not suitable to compensate side loads. The support plunger must not be stressed by tensile load.

The admissible load force is valid for static or dynamic load. Machining forces can generate vibrations, whose amplitude exceeds far an average value, and this can cause yielding of the support plunger. Remedy: increase the safety factor or the number of work supports. In case of accumulation of very small grinding swarf there can be a swarf holdup in the area of the metallic wiper edge. Remedy: Regular cleaning in this area.

Work supports must only be operated with a sealed contact bolt. For special versions of contact bolts we can provide you a drawing with the interior contour.

Operating conditions, tolerances and other data see data sheet A 0.100.

Installation and connecting possibilities

Drilled channels

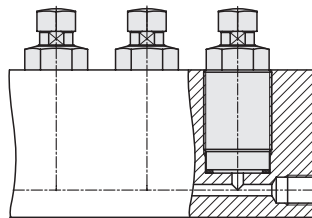

Pipe thread

with accessory mounting body with exterior thread with flange

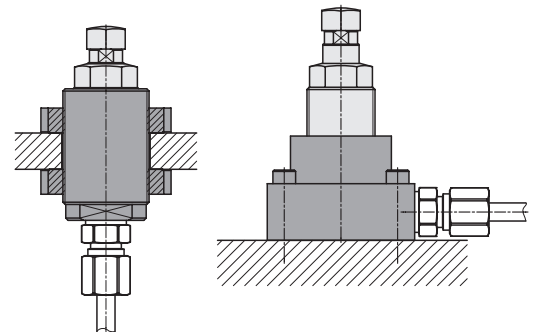

Combination with clamping elements

Load and clamping forces have to be adapted to each other, so that there will be sufficient force reserve available for the threaded-body work support to absorb the machining forces.

Rough estimate:

Min. load force $\geq 2 \times$ clamping force

The opposite diagram shows the course of the load and clamping force for the possible combination of 194X-01X with a threaded-body swing clamp 1891-XX1 as per data sheet B 1.891. The vertical distance of the two straight lines in the area of the colorised surface indicates the maximally possible machining force including reserve.

Example

Threaded-body swing clamp 1891-101 and threaded-body work support 1942-012. Operating pressure 200 bar
As per diagram:

Adm. load force	3.0 kN
- Clamping force	1.5 kN
Possible machining force	1.5 kN

If this force is not sufficient the work support can also be supplied with 500 bar. The pressure for the swing clamp will be reduced.

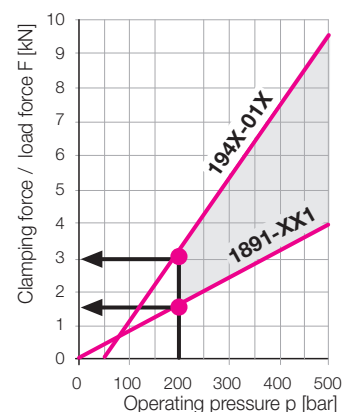
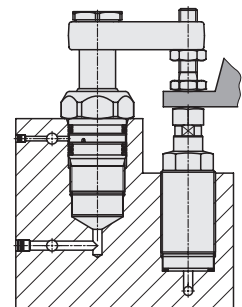



ROEMHELD

Dimensions Technical characteristics Accessories

Spring force

Off-position: Plunger extended
Contact with spring force

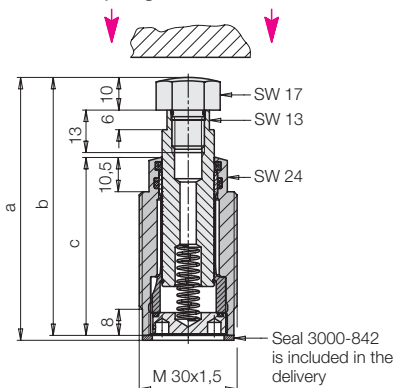

Adm. load [kN]	6.5	9.5
Stroke [mm]	8	8
a [mm]	80.5	90.5
b [mm]	79	89
c [mm]	54.5	64.5

Spring force min./max. [N]	7/12	7/12
Part-no.	1940-002	1940-012

Accessory

Accessory	Part-no.
Mounting body flange	3467-111
Mounting body M38 x 1.5	3467-086
Lock nut M38 x 1.5	3300-088

Air pressure

Off-position: Plunger retracted
Extend and contact with air pressure

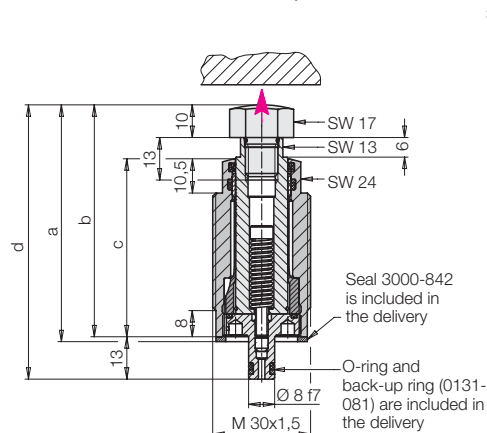

Adm. load [kN]	6.5	9.5
Stroke [mm]	8	8
a [mm]	72.5	82.5
b [mm]	71	81
c [mm]	54.5	64.5
d [mm]	84	94

Spring force min./max. [N]	20/30	20/30
Part-no.	1941-002	1941-012

Oil pressure combined with spring force

Off-position: Plunger retracted
Extend with hydraulic and contact with spring force

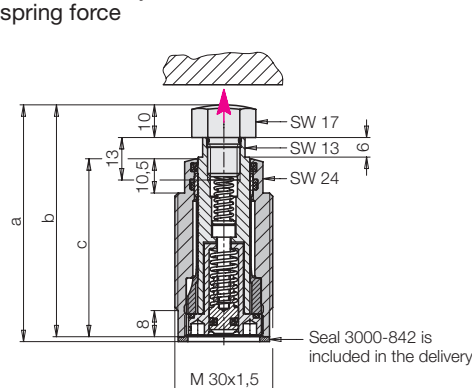

Adm. load [kN]	6.5	6.5	9.5	9.5
Stroke [mm]	8	15	8	15
a [mm]	72.5	79.5	82.5	89.5
b [mm]	71	78	81	88
c [mm]	54.5	61.5	64.5	71.5

Spring force min./max. [N]	16/33	10/22	16/33	10/22	
Part-no.	1942	-002	-007	-012	-017

Porting details for 1940 and 1942

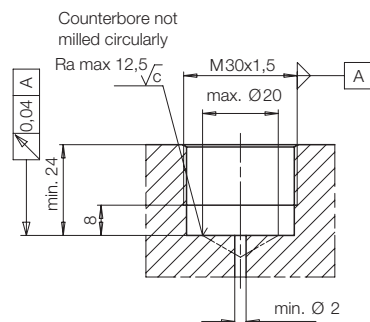

Porting details for 1941

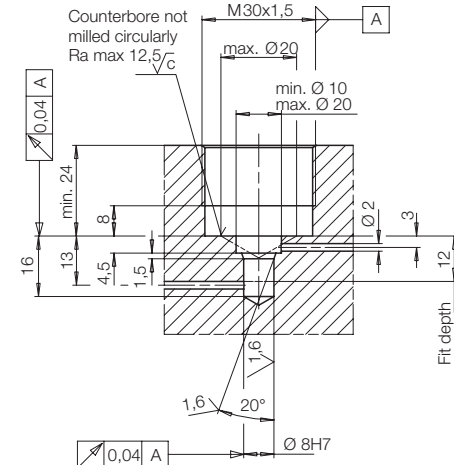

Mounting body flange

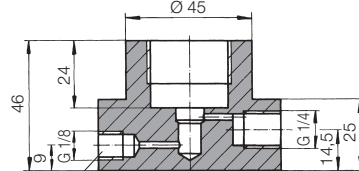

only with 3467-112 (for 1941)

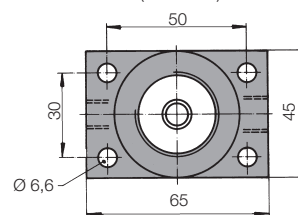

Technical characteristics

Support plunger Ø [mm]	16
Stroke [mm]	8/15
Required oil per stroke [cm³]	0.5/1
Admissible flow rate* [cm³/s]	25
Plunger contact force at 1 bar [N]	20
Air pressure (1941-) (deduct spring force!) [bar]	100
Elastic deformation with load and 500 bar [mm/kN]	0.004
Max. operating temperature [°C]	80
Seating torque [Nm]	60
Weight, approx. [kg]	0.3

* If required insert sharp-edged orifice Ø 0.5 mm in sealing ring (see accessory 1942)

Admissible load force F as function of the operating pressure p

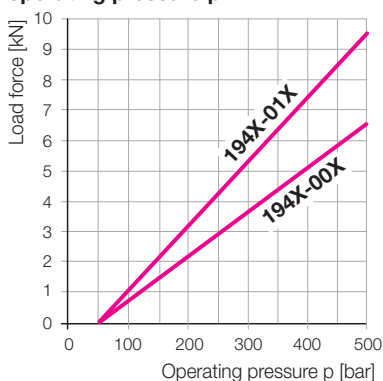

Mounting body M38x1.5

